



# INSTRUCTION MANUAL CZ23000 SERIES



CZ02408-02



Congratulations on your purchase of an Aegis Pty Ltd  
**QuickSwitch™**

We are sure you will be satisfied with its performance and reliability.

Please read this instruction carefully before using your  
**QuickSwitch™** and refer to these notes from time to time to ensure  
you are always familiar with its operation.

This Operators Manual covers the full CZ23000 Series of  
QuickSwitch™. Refer to Section 2, for further details of each type



### **Safety Warning**

**Ensure the QuickSwitch™ (with already attached accessory plug), is plugged into the IDS Module before any other connection is made.**

**Care must be taken at all times to ensure personal safety.**

Aegis Pty Ltd can also supply many instruments for a number of applications to support installation and maintenance of cabling for the Telecommunications, Data and Electrical industries.

If you require further information on any of these instruments please contact us by way of phone, fax or e-mail.

**Unit 9, 173-181 Rooks Road, Vermont, Victoria 3133 AUSTRALIA**  
**TELEPHONE: (03) 8872 6666 FACSIMILE: (03) 8872 6678**  
**International Prefix +613**

Email: [sales@aegis.net.au](mailto:sales@aegis.net.au)

WEB: [www.aegis.net.au](http://www.aegis.net.au)



## Table of Contents

<b>1. SAFETY WARNINGS .....</b>	<b>4</b>
1.1. Warning Note .....	4
1.2. Warning High Test Voltages.....	5
<b>2. INTRODUCTION.....</b>	<b>5</b>
2.1. Intended use of QuickSwitch™ .....	5
2.2. Tests and Functions performed .....	6
2.3. Major features of the QuickSwitch™ .....	6
2.4. Abbreviations and Definitions .....	6
<b>3. GENERAL OPERATION EXPLANATION .....</b>	<b>7</b>
3.1. Features of the QuickSwitch™ .....	7
3.2. QuickSwitch™ Controls/ Layout.....	7
<b>4. OPERATING INSTRUCTIONS .....</b>	<b>8</b>
4.1. Components Available.....	8
4.2. Switch Positions.....	9
4.3. Use with General Test Equipment. ....	10
4.4. Use with RJ Adaptor. ....	10
<b>5. QUICKSWITCH™ OR ADAPTOR LEAD SETS AVAILABLE .....</b>	<b>11</b>
<b>6. SPECIFICATIONS.....</b>	<b>13</b>
6.1. Electrical .....	13
6.2. Environmental Conditions .....	13
6.3. Physical .....	13
6.4. Functions (QuickSwitch™) .....	13
6.5. Optional Accessories.....	14
6.6. Applicable Standards .....	14
<b>7. CARE AND MAINTENANCE .....</b>	<b>15</b>
7.1. Warranty.....	15
7.2. Maintenance and Servicing.....	15
7.3. Cleaning .....	15
7.4. Calibration.....	15

## 1. SAFETY WARNINGS

\* The **QuickSwitch™** must only be used for the purpose, and in a manner, as described in these instructions. Failing to do so may impair the protection, function of or damage the product.

\* The **QuickSwitch™** must be switched to the Monitor (Bridging) position and plugged into the IDS Module prior to any other connection being made. Ensure all Test equipment or instruments are removed from the **QuickSwitch™** before the lead is either inserted or withdrawn from the IDS Module. Failing to do so may impair the protection provided by the QuickSwitch™.

\* The **QuickSwitch™** offers the greatest protection after being plugged in and all connections are made, therefore the operator must use caution when handling the leads, ensuring the plug or socket contacts are not touched.

There are four warnings to be noted when using the QuickSwitch™. All relate to the connection interfaces which are highlighted by either of the following symbols on the switch base or connector head:



1. This symbol alerts the operator to refer to a Note in this handbook. **(Warning Note, See Section 1.1)**



2. This symbol alerts the operator that High Test Voltages may be present at this connection interface. **(Warning High Test Voltages, See Section 1.2)**

### 1.1. Warning Note

When making any connection with QuickSwitch™, be aware that hazardous voltages may exist on the IDS terminal unit, cable pair or test leads of the equipment being used.

The **QuickSwitch™** offers the greatest protection after being fully connected and all connections are made, therefore the operator must use caution when handling the leads, ensuring the plug contacts are not touched. **See Figure 1.1-1**

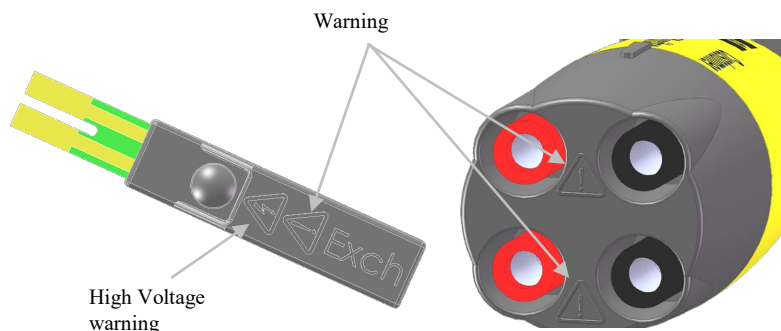

**Figure 1.1-1 Warning & High Voltage warning symbols on the connection Interfaces.**



## 1.2. Warning High Test Voltages

It is important to recognize that any electrical/electronic system may present hazardous voltages. When making connection with the QuickSwitch™, care must be taken not to contact any potentially live parts. See **Figure 1.1-1**

## 2. INTRODUCTION

### 2.1. Intended use of QuickSwitch™

The QuickSwitch™ is intended for use by service personnel on the telecommunications network and under normal conditions is exposed to telecommunications network voltages. Should a fault condition occur with hazardous voltages on the network, the QuickSwitch™ offers protection to service personnel in form of basic insulation to a working voltage of 300 Vrms CAT II. The QuickSwitch™ is a connection tool for telecommunications networks. The QuickSwitch™ incorporates a rotary action control switch, which allows the operator to access a cable pair at an MDF, or CCU, etc., and in turn Monitor the cable pair before performing any test.

The operator then uses the switch to select the direction to conduct a test from this test point, either back towards the Exchange or out towards the Customer.

An additional feature of the QuickSwitch™ is that they can also be used to access the Exchange side and Country side simultaneously.

<u>Part Number</u>	<u>Terminal Access:</u>
CZ23001	QuickSwitch™.
CZ23002	QuickSwitch™ Adaptor Siemens Series 71 Plug
CZ23003	QuickSwitch™ Adaptor Siemens Series 2000 Plug
CZ23004	QuickSwitch™ Adaptor Siemens Series 5000 Plug
CZ23005	QuickSwitch™ Adaptor Crocodile Clips (4) Plug
CZ23006	QuickSwitch™ Adaptor Krone Plug
CZ23007	QuickSwitch™ Adaptor Madison Plug
CZ23008	QuickSwitch™ Adaptor Plug 3M (Quante)
CZ23009	QuickSwitch™ Adaptor Plug Marconi
CZ23011	QuickSwitch™ Adaptor Plug RJ
CZ23012	QuickSwitch™ Carry Pouch

#### Adaptor Leads available:

CZ2280	Banana Plug to RJ Plug (Butt Lead)
CZ2285	Banana to RJ Socket Adaptor Lead
CZ2301	Earth Plug (Complete Set)

*Note 1: The Adaptor Leads provide test access to RJ sockets for both Data and Telephony circuit testing.*

*Note 2: All leads are supplied individually or as a kit, as required.*



## 2.2. Tests and Functions performed

The **QuickSwitch™** does not actually perform any tests itself, it facilitates the access required to a telecommunications network at a cross-connect point, to allow other test instruments to perform the tests as required.

When switched to the Monitor position, with the appropriate access plug, it can be inserted into the matching IDS module to allow the operator to monitor the line (Cable Pair) under investigation. This test is usually conducted with a Buttinski test set.

By rotating the switch through the available positions marked on the switch body, the operator can then connect other test instruments to conduct the usual line tests to determine the “Line Condition”.

Depending on which way the IDS Module and Access plug is setup, (See sections 4.2, for Accessing Exchange or Customer Side), the operator can select, with the rotary switch, the Exchange or Customer side for testing.

By selecting the Exchange side, the line can be tested utilizing auto test facilities, or simply utilize the normal Exchange functions.

When the Customer Side is selected, the cable section leading out towards the customer can be checked or tested.

In general, the **QuickSwitch™** with all it’s optional plugs, is normally used by any Technician or Communication Officer, in the performance of their duties, where access to the copper line is required at any test point along the line. This can be between and including, the Exchange and the customer’s premises.

## 2.3. Major features of the QuickSwitch™

The major features allow the connection of any standard test instrument to a Telecommunication or Data Network via:

- Line Access, non interrupting, Monitoring
- Access to the Exchange side by simple switching without changing lead connections
- Access to the Customer side by simple switching without changing lead connections
- Access to both the Exchange and Customer individually at the same time, by simple switching without changing lead connections.
- Safety of the Operator from non-standard, dangerous voltages on the line

## 2.4. Abbreviations and Definitions

CAN	Customer Access Network
MDF	Main Distribution Frame
CCU	Cross Connect Unit ( <i>Pillar or Cabinet</i> )
Country	Country Side (also called Customer Side) - Refers to the cable looking away towards the customer, from the test point.
Exchange	(Exchange Side) - Refers to the cable looking back towards the Exchange, from the test point.

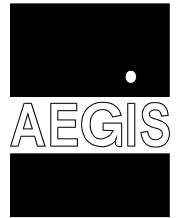

### 3. GENERAL OPERATION EXPLANATION

#### 3.1. Features of the QuickSwitch™

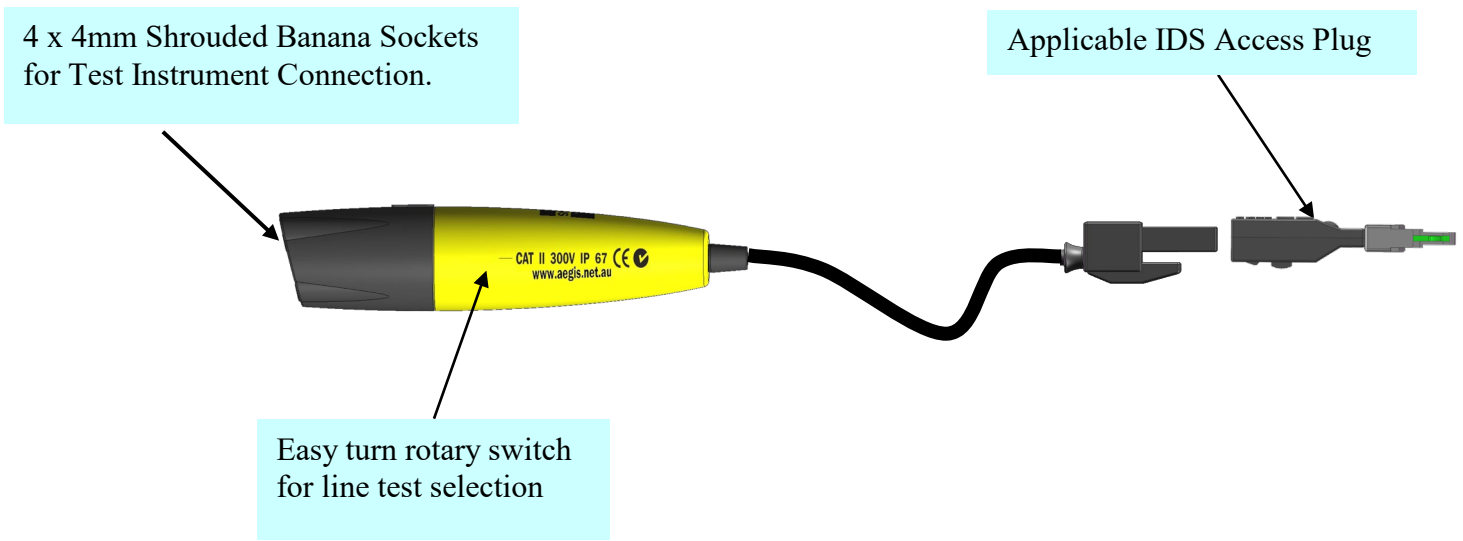

Figure 3.1-1 Features and Application

#### 3.2. QuickSwitch™ Controls/ Layout

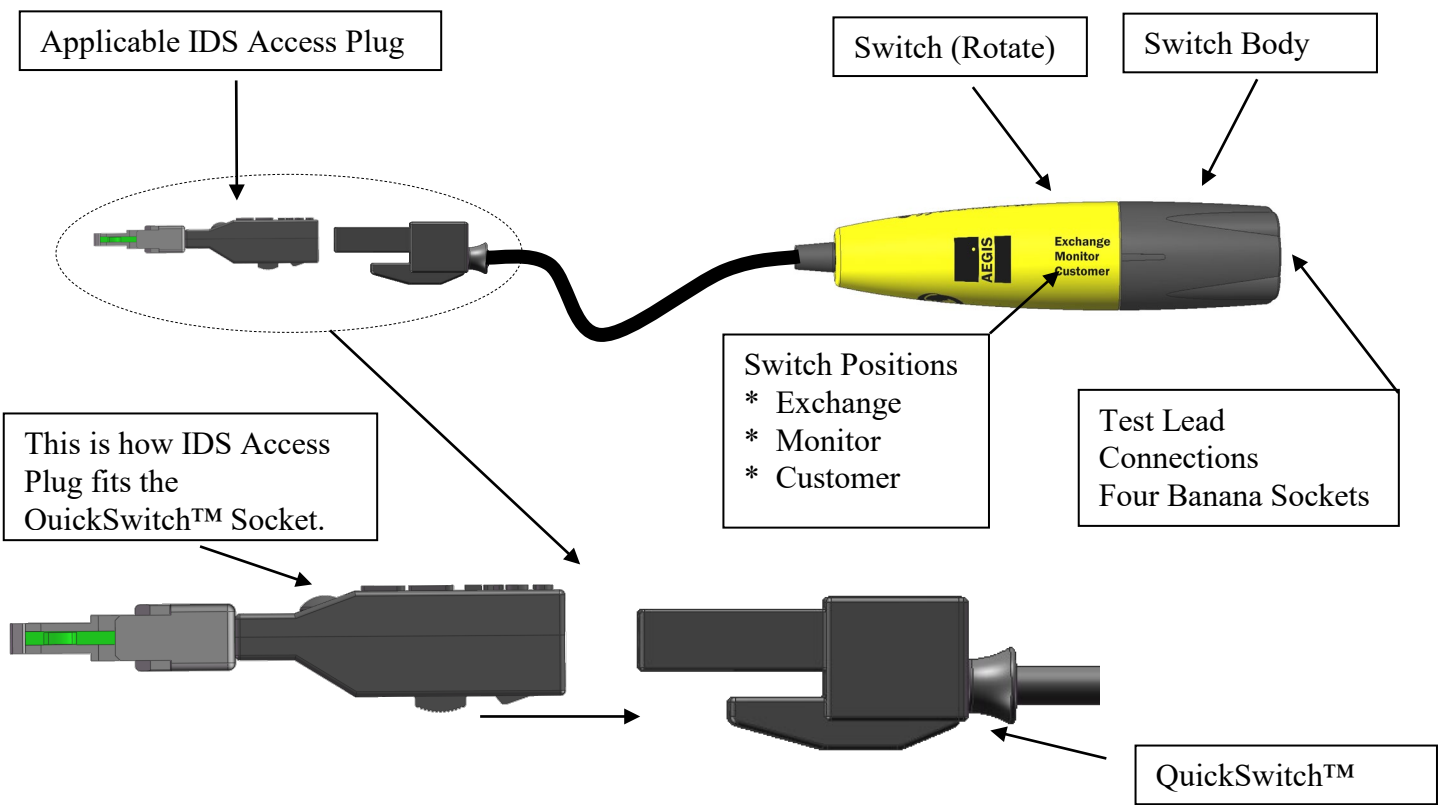

Figure 3.2-1 Controls and Operation

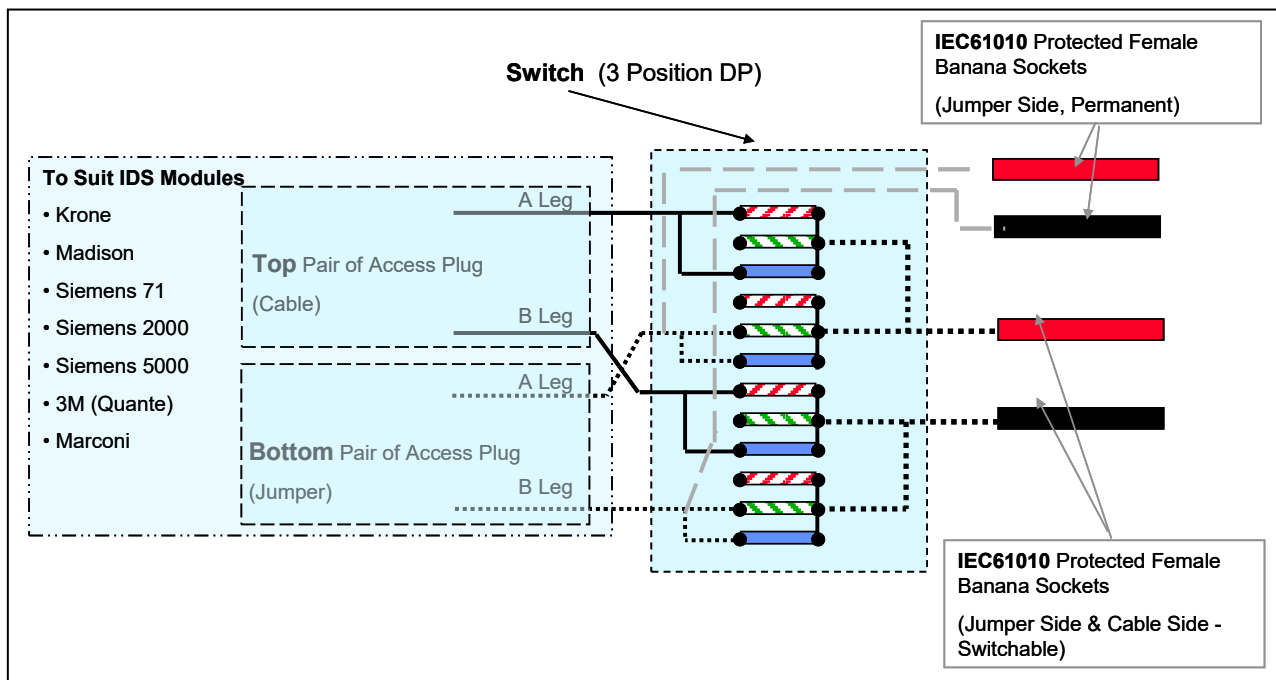

Figure 3.2-2 Switch Operation Diagram.

## 4. OPERATING INSTRUCTIONS

### 4.1. Components Available

The **QuickSwitch™** is available with a range of interchangeable IDS access plugs, contained in a carry bag, or purchased separately.

As each access plug can be purchased separately, refer to the list in section 2.1 for details on the types of switch & adaptor leads available.

This instruction manual is supplied with the **QuickSwitch™**.

The **QuickSwitch™** with the appropriate plug can be used with any test, measure or fault location instrument that is fitted with suitably protected 4mm, male banana plugs that will not exceed the specifications of this lead.



## 4.2. Switch Positions

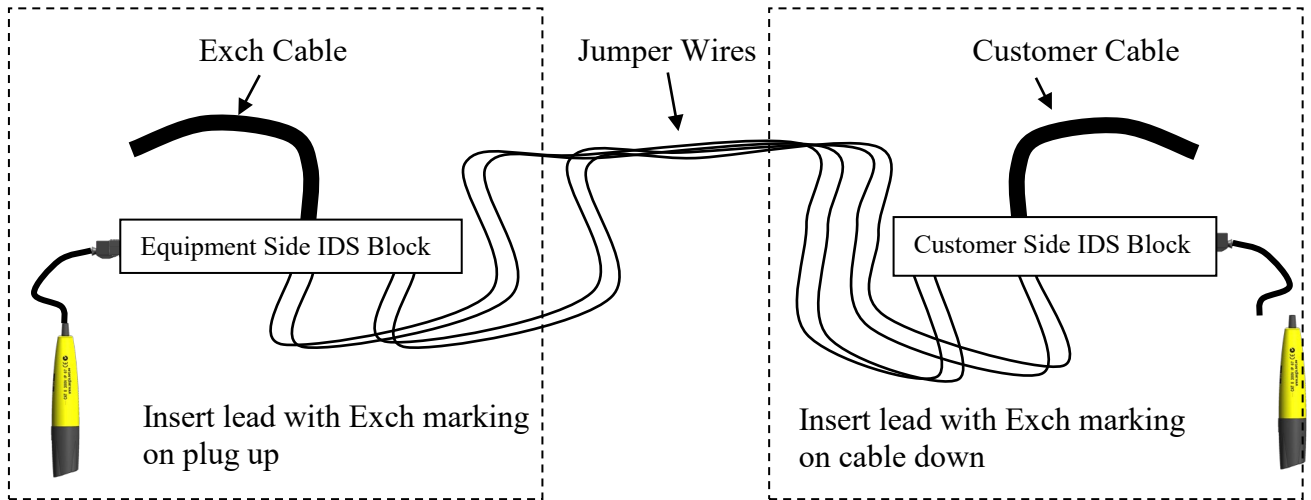

Figure 4.2-1 Switch position for Standard Application of the CAN QuickSwitch™

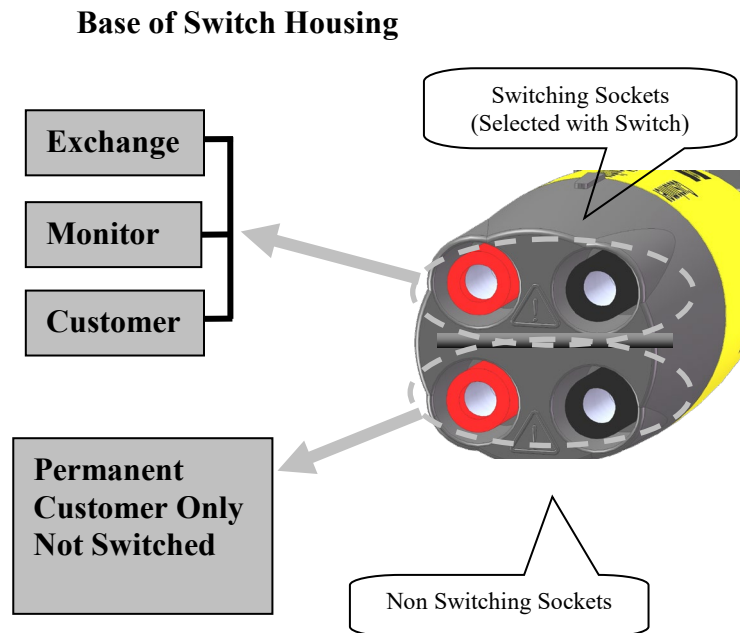

Figure 4.2.2 Connections available at the banana sockets of the QuickSwitch™



#### 4.3. Use with General Test Equipment.

**For connection to the Equipment side of the MDF or Mains side of a CCU**

1. Select the **QuickSwitch™ Plug** to suit the IDS Module you wish to connect to.
2. Ensure the switch is in the Monitor (Bridging) Position.
3. Plug in the **QuickSwitch™** and note the direction of the Exchange.
4. Plug test/monitor instrument into the switching sockets at the base of the switch housing.
5. Unless intentionally being used, ensure the non switching sockets are clear from any other connection.
6. Check the line to ensure it is not in use. (Eg; Buttinski)
7. If a test is to be conducted using an **Exchange** feature or facility, and the **customer** side (Country) is to be **included** in the test, then leave the switch in the **Monitor** position.
8. If a test is to be conducted using an **Exchange** feature or facility, and the **customer** side (Country) is to be **excluded** in the test, then rotate the switch to the **Exchange** position.
9. If a test is to be conducted using a **Country** feature or facility, and the **exchange** side is to be **excluded** in the test, then rotate the switch to the **Customer** position.
10. Ensure all connections are removed from the **QuickSwitch™** before it is removed from the IDS Module.

#### 4.4. Use with RJ Adaptor.

1. When using the RJ Adaptor, make sure that the **QuickSwitch™** must be set to Monitor position.

## 5. QUICKSWITCH™ OR ADAPTOR LEAD SETS AVAILABLE

The CZ23000 QuickSwitch™ utilizes one QuickSwitch™ and various access plugs.

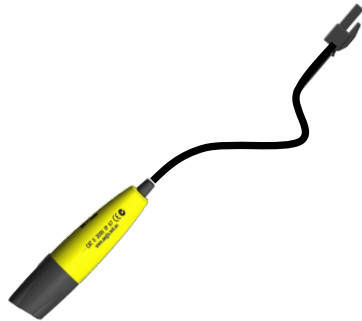

**Figure 5-1 CZ23001,  
QuickSwitch™**

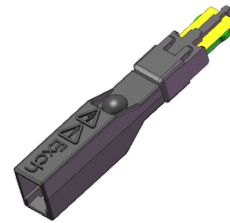

**Figure 5-2 CZ23006, Plug  
KRONE**

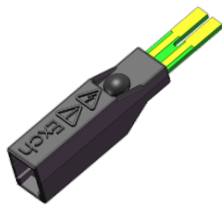

**Figure 5-3 CZ23007 Plug  
Madison**

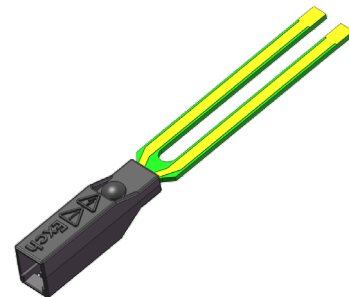

**Figure 5-4 CZ23002 Plug  
Series 71**

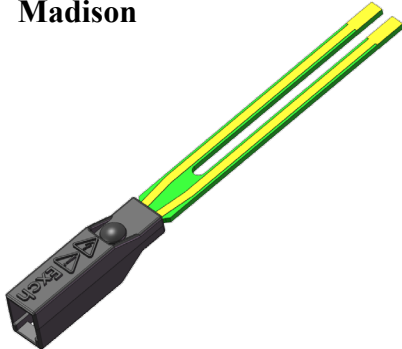

**Figure 5-5 CZ23003 Plug  
Siemens Series 2000**

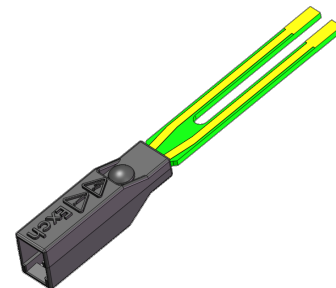

**Figure 5-6 CZ23004 Plug Siemens  
Series 5000**



**Figure 5-7 CZ23008 Plug  
Quante**

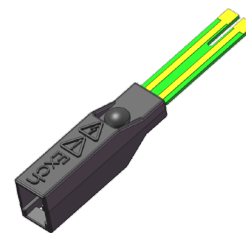

**Figure 5-8 CZ23009 Plug  
Marconi**



**Figure 5-9 CZ2170 S/N 138/98  
LTS No.2 Lead**



**Figure 5-10 CZ23011, Plug  
RJ**



**Figure 5-11 CZ2301 Earth  
Plug Banana Socket – GPO**

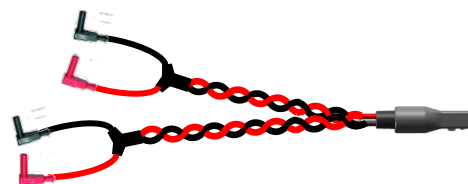

**Figure 5-12 CZ23005, Crocodile  
Clip Adapter**



**Figure 5-13 CZ2285, Banana to  
RJ Socket, Adaptor Lead**



**Figure 5-14 CZ2280 RJ Plug to two  
protected male banana plugs. Butt  
Lead.**  
*This lead is suitable for Buttinskis with  
replaceable RJ socketed leads.*



**Figure 5-15 CZ2150 DC Charge  
Lead S/N 5/00121**



## 6. SPECIFICATIONS

### 6.1. Electrical

Voltage:	Maximum 300Vrms / D.C.
Current:	Maximum 0.5A
Transient Over Voltage:	Maximum 2500V (Rating CAT II)

### 6.2. Environmental Conditions

Location for use:	Indoors or Outdoors
Altitude:	Up to 2000m Elevation
Temperature:	Operating 0°C to +50°C Storage -20°C to +70°C
Humidity:	95% RH non-condensing
Pollution Degree:	Degree 2, as defined in AS61010.1-2003

### 6.3. Physical

Dimensions:	Total 1800 mm. in length Switch 120mm x 28mm
IP Rating:	67 (Switch Housing)
Mass:	100gms

### 6.4. Functions (QuickSwitch™)

Three (3) positions Rotary Switch with IDS Access plugs.

Position 1	Exchange – Top pair of contacts on the IDS Access Plug.
Position 2 (Centre)	Monitor – Combined Top & Lower contacts of the IDS Access Plug
Position 3	Customer - Lower pair of contacts on the IDS Access Plug



## 6.5. Optional Accessories

<i>Description</i>	<i>Qty</i>	<i>Part No</i>
QuickSwitch™ Carry Case	1	CZ23012

## 6.6. Applicable Standards

All equipment offered complies with the relevant parts of the following standards and any further referenced standards within those standards.

1. AS 1099.2.31 – 1990: Basic environmental testing procedures for electrotechnology. Part 2: Tests - 1099.2.31: Test Ec-Drop and topple, primarily for equipment.
2. AS 1939-1990: Degrees of protection provided by enclosures for electrical equipment (IP Code). (Also has been reproduced from IEC 529)
3. AS 60068.2.32-2003: Basic Environmental testing procedures. Part 2. Tests - Test Ed: Free fall.
4. AS/NZS 60950.1: 2003: (Inc. Amdts 1,2 & 3): Information Technology Equipment – Safety. Part 1: General
5. AS 61010.1 (2003): Safety requirements for electrical equipment for measurement, control, and laboratory use – General Requirements.
6. AS 61010.2-31(2004): Safety requirements for electrical equipment for measurement, control, and laboratory use-Part 031: Safety requirements for handheld probe assemblies for electrical measurement and test.

Manufactured under a Quality System complying to ISO9001 (QEC Lic.5948)

*\*\* These specifications and part numbers are subject to change without notice\*\**



## 7. CARE AND MAINTENANCE

### 7.1. Warranty

The **QuickSwitch™ & Adaptor Leads** are warranted against defects in materials and workmanship for a period of 12 months from the date of purchase. If AEGIS PTY LTD receives notice of such defects within the warranty period, AEGIS shall, at its discretion, either repair or replace the defective unit. For purposes of warranty repair or replacement, the user is required to return the defective item together with proof of purchase, to AEGIS at the address given in section 7.2 below. The warranty does not apply for defects or damage arising from misuse by the user.

### 7.2. Maintenance and Servicing

The **QuickSwitch™ & Adaptor Leads** contain no user-serviceable parts, and damaged or failed instruments should be returned to the manufacturer for repair. Such units should be suitably packaged and sent by pre-paid parcel post or courier to the address below:

**Aegis Pty Ltd.**  
**Unit 9, 173-181 Rooks Rd,**  
**Vermont Vic. 3133 Australia**

**Phone 1300 723 447**

**Tel : +61-3- 8872 6666**  
**Fax: +61-3- 8872 6678**

**Email: [sales@aegis.net.au](mailto:sales@aegis.net.au)**  
**Website: [www.aegis.net.au](http://www.aegis.net.au)**

The sender's name and return address must be supplied, together with a description of the fault. If different from the return address, an invoicing address should also be given.

### 7.3. Cleaning

Do not immerse the **QuickSwitch™ or Adaptor Lead** in water.

To clean, simply wipe over with a damp cloth.

Do not use any harsh detergents or solvents on the **QuickSwitch™ or Adaptor Lead**.

### 7.4. Calibration

Not required.

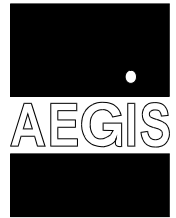

**Notes:**

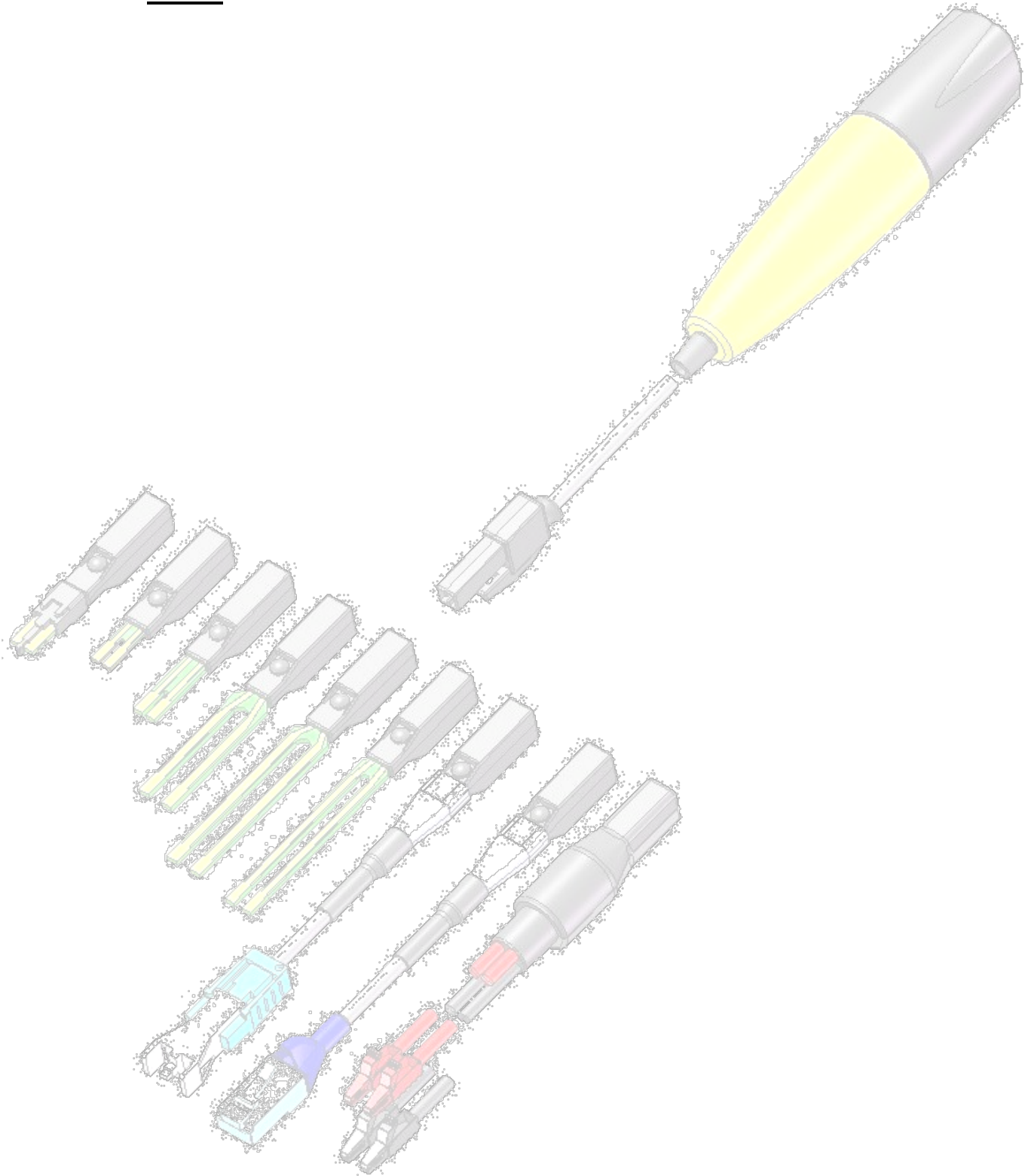



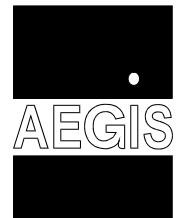

<u>Serial/Item No</u>	<u>Aegis Part Number</u>	<u>IDS Access Plugs Available</u>
005/00742	CZ23001	QuickSwitch™
005/00743	CZ23002	QuickSwitch™ Adaptor Siemens Series 71
005/00744	CZ23003	QuickSwitch™ Adaptor Siemens Series 2000
005/00745	CZ23004	QuickSwitch™ Adaptor Siemens Series 5000
005/00746	CZ23005	QuickSwitch™ Adaptor Crocodile Clips (4),
005/00747	CZ23006	QuickSwitch™ Adaptor Krone
005/00748	CZ23007	QuickSwitch™ Adaptor Madison
005/00749	CZ23008	QuickSwitch™ Adaptor 3M (Quante)
005/00750	CZ23009	QuickSwitch™ Adaptor Marconi
005/00751	CZ23011	QuickSwitch™ Adaptor RJ
005/00752	CZ23012	QuickSwitch™ Carry Case

**Adaptor Leads available:**

5/00110	CZ2280	Banana Plug to RJ Plug (Butt Lead)
5/00111	CZ2285	Banana to RJ Socket Adaptor Lead
5/00108	CZ2301	Earth Plug (Complete Set)

**Unit 9, 173-181 Rooks Road, Vermont, Victoria 3133 AUSTRALIA**  
**TELEPHONE: (03) 8872 6666 FACSIMILE: (03) 8872 6678**  
**International Prefix +613**

Email: [sales@aegis.net.au](mailto:sales@aegis.net.au)

WEB: [www.aegis.net.au](http://www.aegis.net.au)